

CRYOGENIC CENTRIFUGAL PUMPS

SGM SERIES

FOR LIQUEFIED NATURAL GAS (LNG)

TECHNICAL FEATURES

- Electric motor and gearbox transmission
- Mechanical seal in rulon
- Inducer to minimize required NPSH
- Low noise emission (< 80 dB)

APPLICATIONS

- Road trailers unloading, storage/iso-containers loading/unloading
- Process and back-up operations, petrochemical industry applications
- Special applications with differential head and flow rates upon customer demand

TRANSFERRED FLUIDS

- LNG

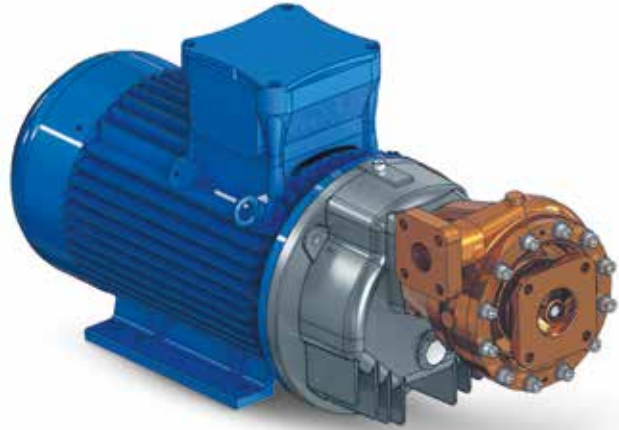
**SGM SERIES PERFORMANCES**

Model		SGM 160	SGM 185	SGM 200
Power installed (Motor frame)	Pm [kW]	11 - 15 - 18,5 (160)	11 - 15 - 18,5 (160)/ 22 (180) - 30 - 37 (200)	22 (180)/30 - 37 (200)
Max operating speed (50 Hz)	rpm	7310	8550	6910
Max suction pressure	P [bar]	6	6	6
Max allowable working pressure	MAWP [bar]	30	23/33*	23
Max head (50 Hz)	DH [m]	225	420	300
Max flow rate (50 Hz)	Q [lpm]	520	650	950

*Aluminium pump casing (23 bar) and bronze pump casing (33 bar)

Data can be subjected to change

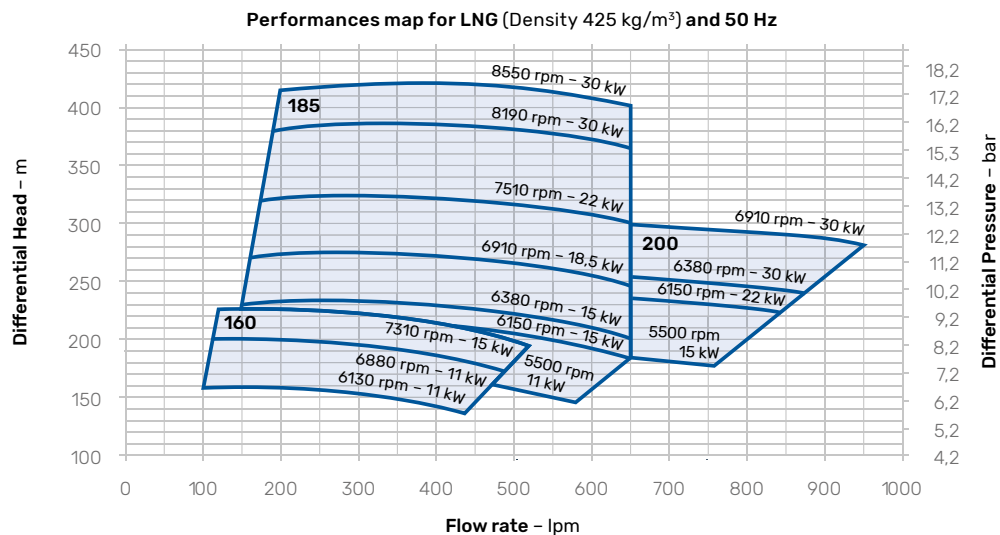

OPTIONAL ACCESSORIES

- Counter flanges
- Filter
- Flexible hoses for suction and discharge lines
- Leakage detection by temperature sensor
- Flushing system with nitrogen gas
- Temperature sensor for cooling down
- Electrical control panel
- Motor suitable for VFD
- Completely automated systems available on demand
- Mobile skid available on demand
- Temperature sensor of bearing casing

TEST AND CHECKS

- Dimensional control of each mechanical component before assembly
- Running test of each pump with LIN before delivery

STANDARDS

Designed according to:

- European Directive Machinery
- European Directive ATEX
- EIGA/IGC/CGA guidelines



GENERAL DIMENSIONS

SGM 160

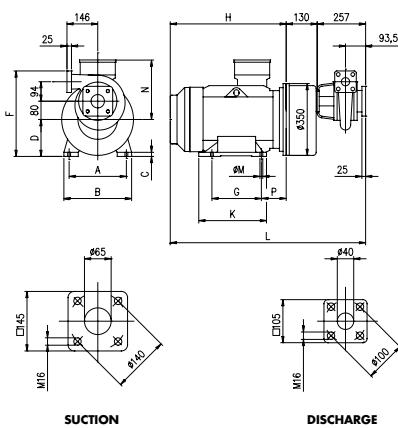

SGM 185

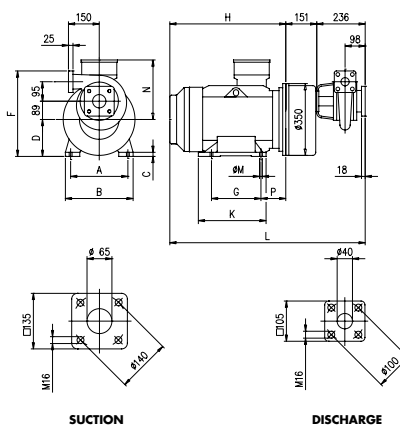

SGM 200

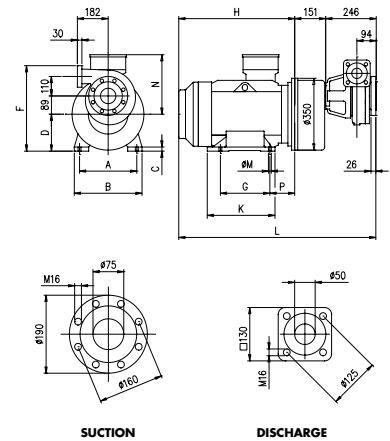

SGM 160

Available motor power [kW]	Motor size	A	B	C	D	F	G	H	K	L	M	N	P	Weight [kg]
11/15/18,5	160	254	318	15	160	387	210	583	305	970	14	290	108	145

SGM 185

Available motor power [kW]	Motor size	A	B	C	D	F	G	H	K	L	M	N	P	Weight [kg]
11/15/18,5	160	254	318	15	160	397	210	583	305	970	14	290	108	145
22	180	279	350	17	180	417	241	704	340	1091	14	326	121	220
30/37	200	318	393	18	200	437	305	790	360	1176	18	346	151	270

SGM 200

Available motor power [kW]	Motor size	A	B	C	D	F	G	H	K	L	M	N	P	Weight [kg]
22	180	279	350	17	180	397	210	704	340	1101	14	326	121	340
30/37	200	318	393	18	200	464	305	790	360	1187	18	346	166	395

Data can be subjected to change



Certified quality management system