

CRYOGENIC RECIPROCATING PUMPS

VT-1 SERIES

FOR LIQUEFIED NATURAL GAS (LNG)

TECHNICAL FEATURES

- Compatible with Cold Converter and Thermosyphon storage tanks
- Easy installation thanks to 360° rotating inlet and outlet connections
- High efficiency
- Low operating noise
- Quick maintenance thanks to the integrated cartridge seal system

APPLICATIONS

- L-CNG refuelling stations for cars/trucks/buses, cylinders and buffer filling

CRANKDRIVE LUBRICATION

- TW 6,5 – Oil lubrication

TRANSFERRED FLUIDS

- LNG

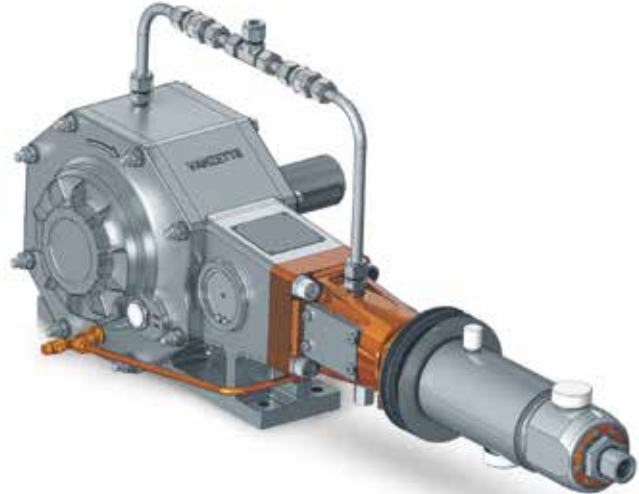
**VT-1 TW 6,5 PERFORMANCES**

Model	Piston		Flow rate				Maximum allowable suction pressure (MASP)		Maximum allowable working pressure (MAWP)		Power installed
	Bore	Stroke	Min 80 rpm		Max 450 rpm		bar	psi	bar	psi	Referred to MAWP
Series pump	mm	mm	lpm	gpm	lpm	gpm					kw
VT-1 32 25	32	25	1,4	0,4	8,1	2,1	20	290	420	6092	3 - 15
VT-1 32 35	32	35	2,0	0,5	11,4	3,0	20	290	420	6092	4 - 22
VT-1 34 35	34	35	2,3	0,6	12,9	3,4	20	290	500	7252	5,5 - 30
VT-1 36 35	36	35	2,6	0,7	14,4	3,8	20	290	420	6092	5,5 - 30
VT-1 40 35	40	35	3,2	0,8	17,8	4,7	20	290	420	6092	5,5 - 30
VT-1 45 35	45	35	4,0	1,1	22,5	5,9	20	290	320	4641	5,5 - 30
VT-1 48 35	48	35	4,6	1,2	25,6	6,8	20	290	260	3771	5,5 - 30
VT-1 45 40	45	40	4,6	1,2	25,8	6,8	20	290	320	4641	7,5 - 37
VT-1 48 40	48	40	5,2	1,4	29,3	7,7	20	290	260	3771	5,5 - 37

NPSH required: 1,5 - 1,7 m

Data can be subjected to change

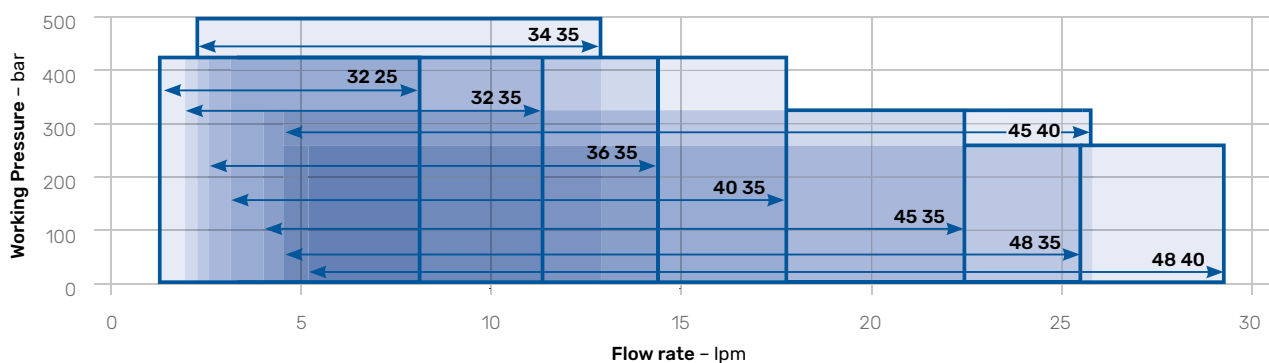

STANDARD SUPPLY

- Painted steel frame
- Cryogenic pump
- Electric motor
- Transmission with belts and pulleys
- Double Pulsation damper

STANDARD ACCESSORIES

- Suction flexible hose
- Return flexible hose
- Low pressure safety valve
- High pressure safety valve
- High pressure pneumatic valve for venting
- Check valve
- Pressure gauge
- Pressure switch
- Temperature sensor for cool down
- Temperature sensor for cavitation
- Temperature sensor for leaks detection

OPTIONAL ACCESSORIES

- Flushing system with nitrogen gas
- Electrical control panel
- 2 speed electric motor
- Motor suitable for VFD
- Complete automatic system available on demand

Average SKID weight: 690 kg

Package overall dimensions: 195 x 95 x 130 cm

TEST AND CHECKS

- Dimensional control of each mechanical component before assembly
- Performance test with LIN available for class and customer

STANDARDS

Designed according to:

- European Directive Machinery
- European Directive PED
- European Directive ATEX
- EIGA/IGC/CGA guidelines

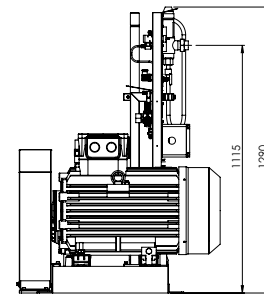
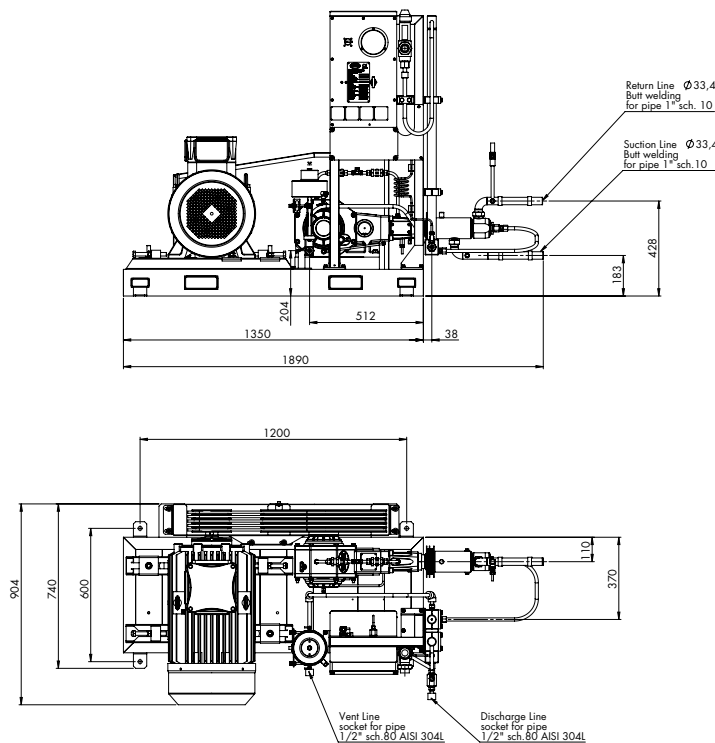

II 2G Ex h IIB/IIC T4 Gb

GENERAL DIMENSIONS**COLD END DETAIL**

The innovative seal cartridge allows a very easy maintenance



Certified quality
management system